



SERENA GROUP
the partner you can trust.

SERENA GROUP Srl

C.F. e Partita Iva 05476450969 - REA MI 1824722
Cap.Soc. Euro 100.000,00 i.v

via Umbria, 24 20090 Segrate (MI)
Tel. +39.02.39810095 - Fax +39.02.26920493
www.serenagroup.eu

I sistemi di gestione di qualità ISO 9001 sono certificati da LRQA
I sistemi di gestione ambientale ISO 14001
I sistemi di gestione della salute e sicurezza sul lavoro ISO 45001
sono certificati da AQSCERT
Agenzie Dogane Monopoli codice mecc.co 30766-E Luogo 107045-W

Scheda Tecnica – Sedia Pieghevole in HDPE per Catering

- **Materiale: Struttura in acciaio verniciato antiruggine**
- **Spessore materiale mm 1**

- **Seduta / schienale in HDPE (polietilene ad alta densità)**

- **Design: Sedia pieghevole, facile da riporre e trasportare.**

- **Caratteristiche:**
 - **Resistente a uso intensivo.**
 - **Supporta carichi fino a CD40 kg. 100 / CD49 kg. 120**

 - **Antiscivolo, con piedini in gomma**
 - **Facile da pulire e mantenere.**

- **Dimensioni:**

Item	Descrizione italiana	Volume M3	Weight kg
CD40	Sedia pieghevole cm 43 x 43 x h.83	0,02	3,6
CD49	Sedia pieghevole cm 40 x 42 x h. 86	0,045	5

- **Usò: Ideale per eventi, catering, fiere, e ambienti ad alto traffico.**

CD49



SERENA GROUP

Imported by Serena Group
Via Umbria, 24 20090 Segrate (MI) Italy
Tel. +39.02.39810095 / fax. +39.02.26920493
www.serenagroup.eu - info@serenagroup.eu

86cm
33.8"

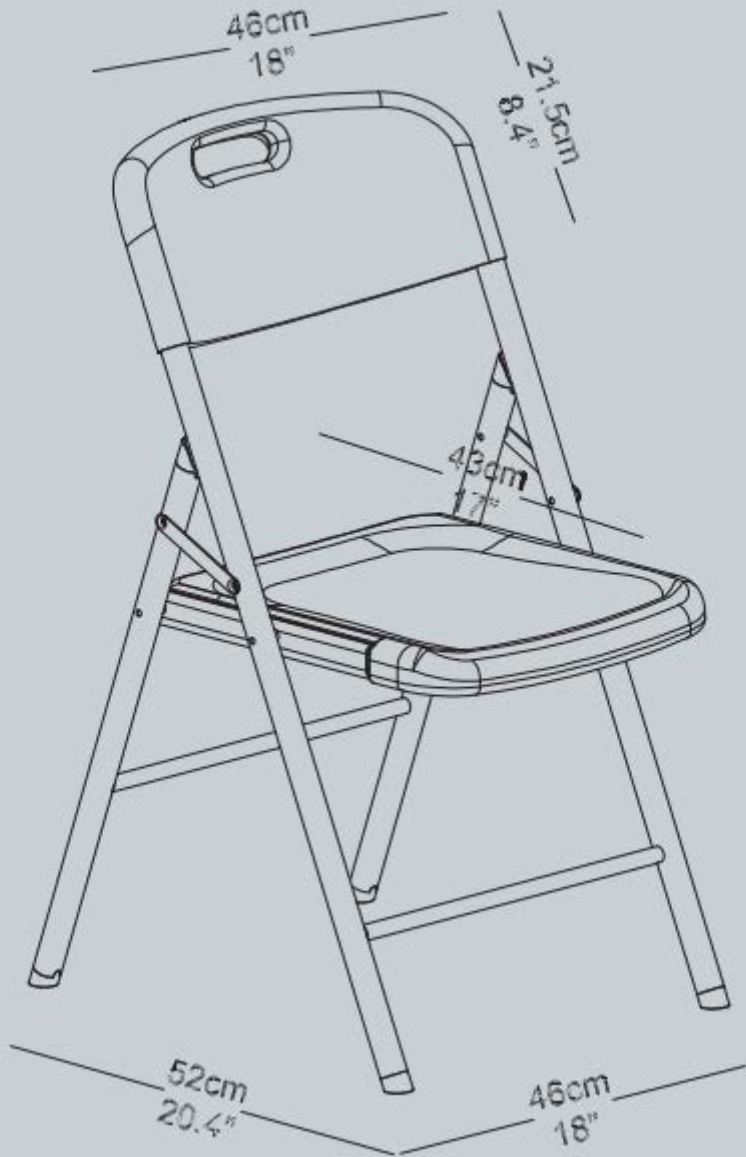

45cm
17.7"

CD40



SERENA GROUP

Imported by Serena Group
Via Umbria, 24 20090 Segrate (MI) Italy
Tel. +39.02.39810095 / fax. +39.02.26920493
www.serenagroup.eu - info@serenagroup.eu

